

Operation of the VT CP-MAS Pencil Probe on the GN300WB

Table of Contents

I. Rotor Description and Packing Procedure	1
II. Spinning and Stopping the Rotor	2
III. Probe Tuning	3
IV. Spin Rate Monitor	3
V. Variable Temperature	3

I. Rotor Description and Packing

The 7.5 mm diameter rotor for the pencil probe consists of four parts: (1) a zirconia rotor sleeve, (2) a Kel-f drive tip, (3) a teflon front spacer and (4) a teflon endcap. The maximum spinning rate of the rotor is 7 kHz using nitrogen gas from high pressure tank and 6 kHz using the nitrogen gas from building supply. The sample coil extends over only the active volume as shown in the figure below.

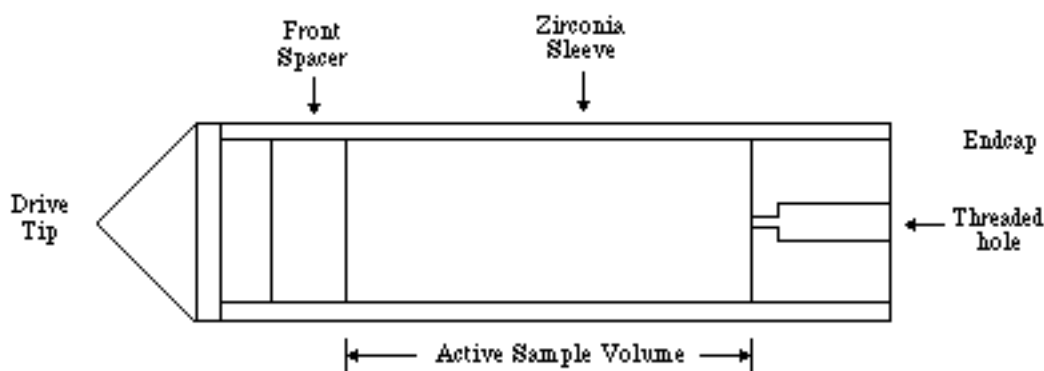

The rotor can be disassembled for cleaning by removing the endcap with an endcap extractor tool. You should never remove the drive tip since repeated removal will spoil the tight fit.

A worn drive tip may be replaced by removing it with the drive tip wrench, preferably after immersing the tip into liquid nitrogen to shrink it. When reassembling, put the front spacer in first and then use the drive tip to push it in as you install it. This eliminates any excess air gap between the parts. This procedure should only be performed by lab staff.

For sample packing, remove the endcap using the endcap extractor tool and place the rotor nose down into the packer. Ground the sample to fine particles otherwise the rotor would start spinning. Add small amounts of sample and pack it down with the tamper. Be careful not to overfill the rotor so that the endcap can fit entirely within the sleeve. NOTE: SPINNING THE ROTOR WITH THE ENDCAP PROTRUDING WILL CAUSE THE ENDCAP TO BULGE RESULTING IN ITS UNTIMELY DEMISE! The tamper has a notch in it to indicate the proper packing depth.

Insert the endcap into the sleeve making sure that the threaded hole is facing outward. If the endcap does not fit snugly, place a small piece of teflon tape over the endcap before inserting into the sleeve. Scrape off any excess tape with your thumbnail.

To remove the endcap, screw the extractor tool into the endcap until it seats. Then hold the rotor and knurled nut of the extractor tool stationary while turning the extractor sleeve downward against the rotor (see diagram below). This procedure will pull the endcap straight out of the rotor.

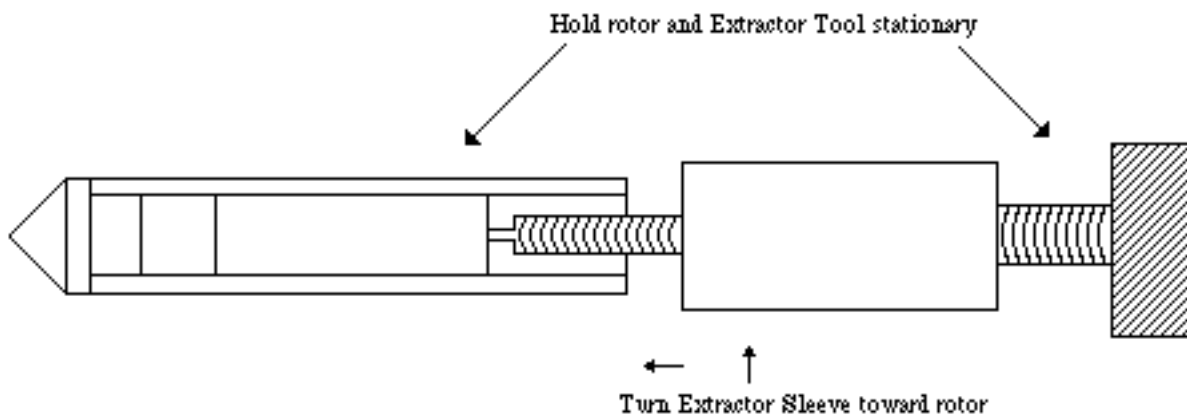

When unpacking the sample, be careful not to scratch the rotor sleeve. Since it is ceramic, a scratch can weaken the structure causing it to fail while spinning.

Drive tip wrenches, endcap extractors and packers can be purchased from MSL personnel. The 7.5 mm zirconia rotor must be purchased directly from Chemagnetics, Inc. See lab staff for ordering information.

II. Spinning and Stopping the Rotor

Before attempting to spin the rotor, inspect the outside for any scratches or abrasions. A scratched rotor may fail while spinning resulting in an explosive release of rotor shards and could cause major probe damage and personal injury. Do not use a rotor if it is found to be defective. Also, due to the ever present potential for rotor failure, never spin the rotor with the probe door open and always wear safety glasses when in the vicinity of the probe.

You merely need to place the rotor nose first into the probe, close the door and raise the probe into the magnet. Turn the bearing pressure up to about 17 psi and then bring the drive pressure up to about 10 psi. The rotor should begin spinning smoothly. If not, turn the driving pressure off and turn up to 10 psi quickly. If still not, you may need to repack the sample or see lab staff to check the rotor.

When increasing the spin rate, do so in small increments. The bearing can be kept at about 17-20 psi while the drive is increased for the desired spin rate. You should take a spectrum at 4 kHz to see the maximum speed is necessary or not. If necessary, set bearing to 20 psi and turn the driving gas to the highest pressure you can get (typically 30 psi and it varies). At this pressure, you should be able to reach 5.6 kHz spinning speed.

When stopping the rotor, leave the probe up in the magnet and slowly decrease the drive pressure so that the rotor does not suddenly crash to a halt. Remember that the rotor is ceramic and could explosively shatter. Keep the probe door closed and wear safety glasses! After the rotor has stopped, lower the probe and open the door. Remove the rotor from the probe by screwing the extractor tool partially into the endcap and pull it straight out. Be careful not to drop it! If drops, report to lab staff immediately, spinning a defected rotor will cause major probe damage.

III. Probe Tuning

The pencil probe is tuned in the same way as the other probes except that a small plastic screwdriver is used to tune and match screws on the side of the probe base. The plastic rod protruding from the bottom of the probe is used for adjusting the magic angle and should not be turned accidentally.

IV. Spin Rate Monitor

The pencil probe is equipped with a fiber optic spin rate monitor. In order for the system to work, you need to make a small black dot on the end of your rotor with a magic marker, as shown below.



Connect the cable from the monitor to the probe base and turn the unit on. The spin rate is displayed in Hz. Do not leave the spin rate monitor on for extended periods of time as it tends to overheat.

V. Variable Temperature

The variable temperature system uses a separate gas stream to heat and cool the middle sample area of the rotor in the probe. The temperature range is -150 °C to 250 °C. The system is diagrammed on the next page:

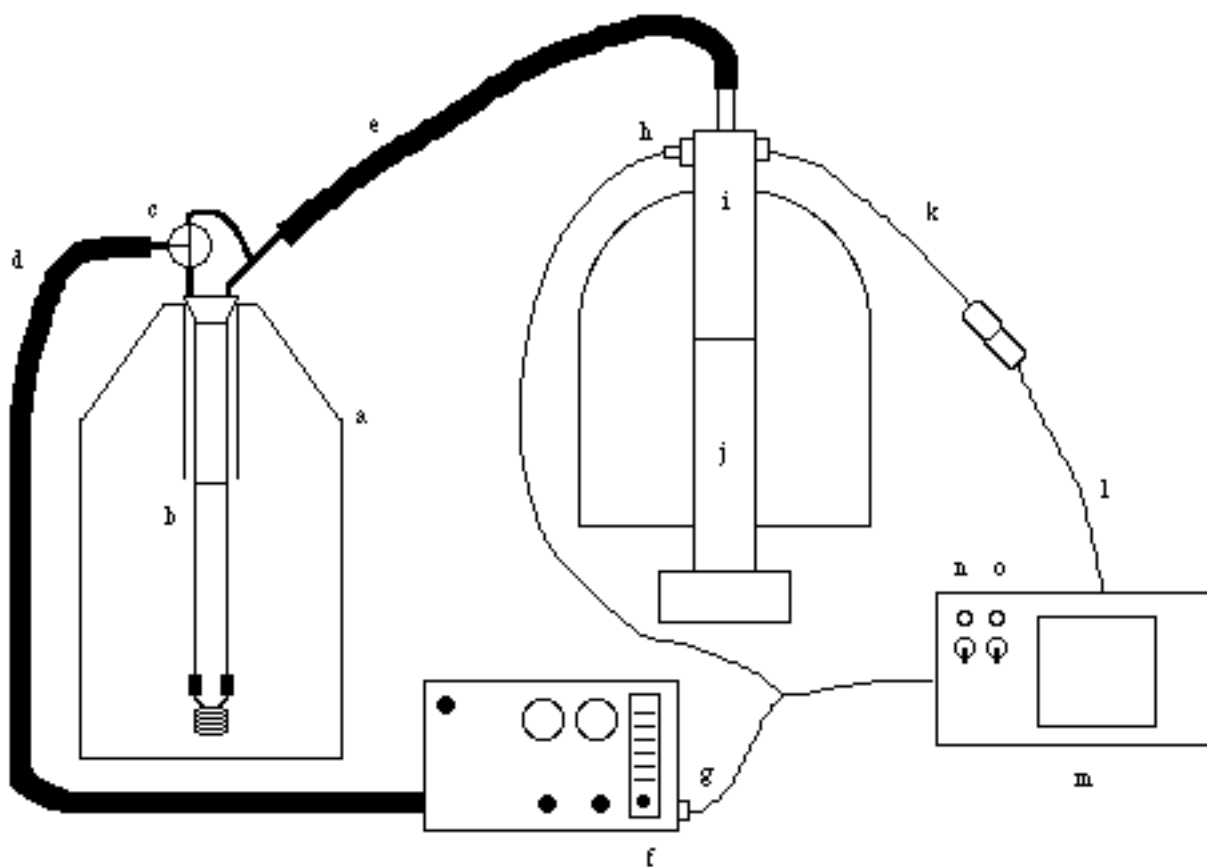

- | | | | |
|---|-------------------------|---|------------------------|
| a | supply dewar | i | heater stack |
| b | heat exchanger | j | pencil probe |
| c | bypass valve | k | heater stack plug |
| d | VT gas line | l | blue heater cord |
| e | VT transfer line | m | temperature controller |
| f | flow meter needle valve | n | heater switch |
| g | air sensor plug | o | power mains |
| h | VT sensor plug | | |

The VT gas is first passed through the liquid nitrogen supply dewar and then through an insulated line to the top of the heater stack. The heater stack is situated inside the magnet bore and mates with the top of the probe when it is raised into the magnet. The VT gas passes through the heater stack, around the middle of the spinning rotor (where the sample is) and exits back out through the heater stack. The VT flow rate is controlled using the flow meter needle valve on the spinner box.

To begin operation, position the probe in the magnet and seat the heater stack into the top of the probe. Start the rotor spinning.

Turn on the "MAINS" switch on the large temperature controller and connect the VT sensor plug to the heater stack and the air sensor plug to the rear of the spinner box. Note: the heater will not come on if the air sensor plug is not connected properly. Do not turn on the heater switch yet. Connect the large blue heater cord (rear of controller) to the heater stack plug.

Set the desired temperature on the controller using the left and right arrow keys to select the digit/sign to be changed and use the up and down arrow keys to raise or lower the number or to change the sign from "+" to "-".

The **SELECT** button is used to check the controller parameters. They should be set to the values indicated below.

H	10	I	45
L	10	D	10
P	500	C	1
A	500		

For low temperature work, fill the supply dewar with liquid nitrogen and connect all the VT gas lines. Turn the VT gas up to about 50 and lower the heat exchanger into the dewar. Make sure that the valve at the top of the heat exchanger is sending the VT gas down through the cooling coil. Place the stopper in the hole in the top of the heat exchanger. The stopper can be removed to allow the supply dewar to be refilled if necessary.

Turn on the heater switch on the temperature controller and verify that you have set the correct temperature. You will need to increase the VT flow as you go to lower temperatures. Retune the probe at each temperature and allow a few minutes for sample equilibration before acquiring data.

For high temperature VT, simply make all the connections without filling the supply dewar. Then turn on the heater and allow the temperature to reach the set point. When the desired temperature is achieved, retune the probe and wait a few minutes for the sample to equilibrate before acquiring data.

While running the VT system, listen to the rotor carefully in case it decides to crash. If it does, stop pulsing immediately and first turn off the heater switch and then the VT gas. Restart the rotor and try again. You do not have to lower the probe. **NEVER PULSE THE PROBE UNLESS THE ROTOR IS SPINNING SMOOTHLY.**

When finished, turn off the heater switch and slowly turn off the VT gas. If you were at low temperature, turn the valve at the top of the heat exchanger so that the VT gas bypasses the cooling coil and slowly turn the VT gas back on to warm the probe to room temperature. The heater can be used to expedite the warmup process but do not use a set point higher than room temperature.

When the probe has equilibrated at room temperature, turn off the heater switch and the "MAINS" switch on the temperature controller. Turn off the VT gas. Disconnect the insulated line from the top of the heat exchanger and remove the coil from the supply dewar. Stop the sample from spinning and lower the probe.